

IMPORTANT GUIDELINES

The Status 530/10 can only be fitted where the Wall Bracket can be fixed to a vertical surface.

The Status 530/5 should only be fitted if there is extra strength in the roof, such as a support or block.

Routing the Coaxial cable

Coaxial Cable is quite fragile and must be handled with care. Please comply with the following as failure to do so will severely affect performance.

1. Should the coaxial plug be removed, it is very important that it is refitted correctly as described below.
2. Do not crush, kink or over-bend the coaxial cable which has a minimum bend radius of 25mm.
3. Any excess cable should be removed and MUST NOT be coiled.

4. Avoid increasing the number of connections or breaks in the coaxial cable as they will reduce performance, especially in weak signal areas.
5. Do not run coaxial cable next to mains cable, leave a minimum distance of 120mm to prevent interference.
6. Do not allow the cable to come into contact with any hot surfaces as this could melt the air-spaced insulation of the cable.
7. Keep away from fluorescent lighting.
8. When installing the coaxial cable, Do not feed through by pulling on the coaxial plug.
9. Do not add excessive lengths of coaxial cable. This will result in increased signal losses and a reduction in picture quality.
10. Should the cable need to be lengthened, use only RF100 specification cable and high quality coaxial plugs and couplers which are available from our Vision Plus range through our dealers or directly from ourselves.

Connecting the Coaxial TV Plug

Should the coaxial plug need to be removed, please note how it comes apart and reassemble as follows:-

1. Prepare the cable by removing 16mm of white outer sheath to expose the braided copper wire.
2. Next, remove 10mm of the exposed braided copper wire and the central air-spaced insulation to expose the single central core.
3. Feed the screw cap 'A' and the pronged clamp 'B' over the cable. Pull back evenly the copper braiding over the pronged clamp as shown below.

IMPORTANT – IT IS CRITICAL THAT NONE OF THE COPPER BRAIDING IS TOUCHING THE CENTRAL CORE.

4. Push on item 'C' up to 'B' and secure the central core by tightening the small grub screw. Be careful not to over tighten, which could sever the wire.
5. Screw 'A' and 'D' together to complete the assembly.

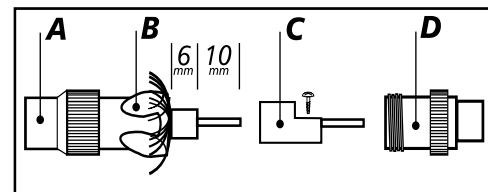

Travelling

DO NOT TRAVEL:-

- With the Antenna raised
- With the Antenna set for vertical signals
- With the Telescopes extended

When travelling adjust the antenna so that it points to the rear of the vehicle to reduce the possibility of damage when travelling.

The **RED SPOT** on the bottom of the mast indicates the front of the Antenna.

ASSEMBLY & INSTALLATION

Assembling the Mast & Antenna

1. Taking the drive-shaft, insert it into the gearbox and rotate anti-clockwise until the Gearbox Mast Adapter has rotated through 90° and is vertical.

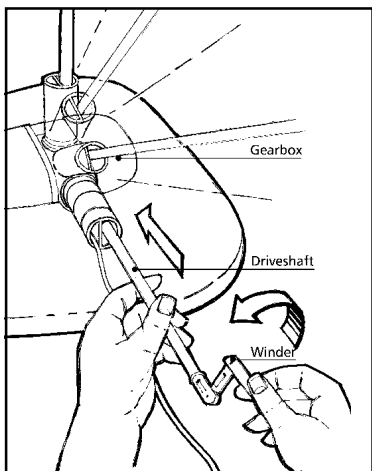

2. Using the Allen Key unscrew the M5 pozi-pan bolt from the Gearbox Mast Adapter.
3. Lower the mast over the coaxial cable and drive-shaft and gently push the mast over the three O-rings with a twisting motion being careful not to trap or damage the O-rings. If necessary use a soapy water solution as a lubricant (DO NOT use oil based lubricants).

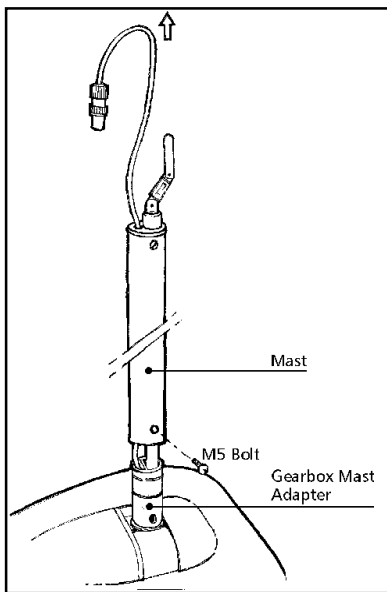

VERY IMPORTANT - When refitting the M5 bolt, the head must be flush with the mast to prevent damage to the gaiter.

IMPORTANT - Ensure the cable and drive-shaft are NOT twisted, but run along side each other.

Positioning

When positioning the Antenna & Mast, please consider the following:-

1. Position in a suitable wardrobe or locker, against an internal wall, away from the edge of the roofline to reduce the possibility of damage when travelling.
2. Wherever possible, mount on the offside of the vehicle to reduce the possibility of collision with overhead obstructions.
3. You must ensure there is enough space for the mast to retract fully and for the location of the Power Pack.
4. Position so that the Antenna Dome is not shielded from incoming TV signals when raised.

Fitting

The Wall Bracket is only supplied with the 530/10 long mast model.

The Mounting Foot tilts, which enables the mast to remain vertical on a sloping surface of up to 15°. If your roof is angled, refer to **Angle Adjustment** below.

1. Position the centre of the hole for the mast 50mm from the wall. Alternatively offer the template up to the ceiling against the wall and drill a **VERTICAL** 45mm diameter hole.
2. On the roof, screw into place the Mounting Plate and foam seal with the three 16mm screws supplied.

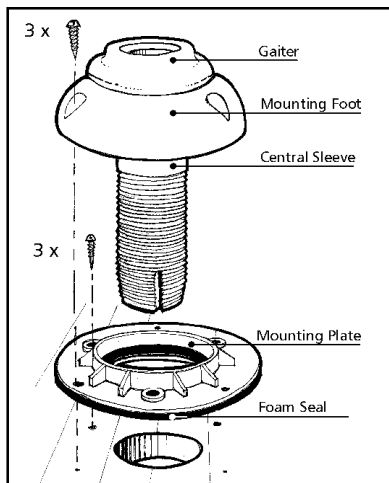

3. Guide the Mounting Foot and Central Sleeve into place and fix with three 32mm screws supplied.
4. Inside the wardrobe, thread the Locking Plate and Tapered Washer up the Central Sleeve to the ceiling and hand tighten. Secure with the three 16mm screws ensuring the Central Sleeve is **VERTICAL**.
5. Once the Locking Plate is in position, tighten the cross screw onto the Central Sleeve to prevent rotation and thread the Mast Locking Collar onto the end of the Central Sleeve.
6. When installing a 530/10, position the Wall Bracket 250mm down from the ceiling, securing in place with the four 38mm screws supplied.
7. Feed the coaxial cable and mast through the Mounting Foot and Wall Bracket* and lower into place.
8. Tighten the Mast Locking Collar and the Wall Bracket to secure the mast.

It is crucial that the mast runs **VERTICAL**.

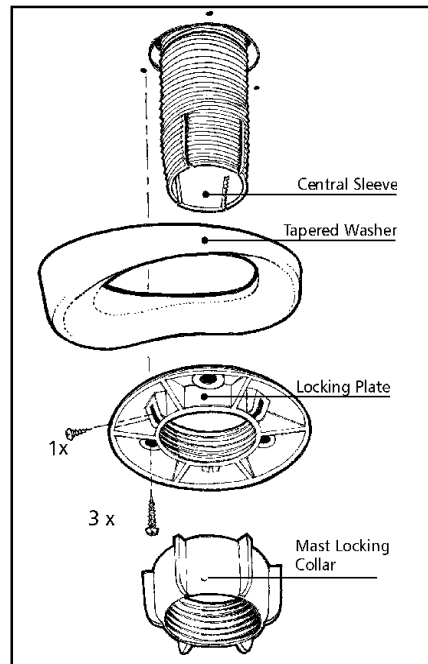

Angle Adjustment.

The Mounting Foot is designed to pivot on the Mounting Plate to allow for level fixing on a sloping surface.

1. To adjust, twist the Central Sleeve around inside the gaiter until the direction of tilt lines up with the line of fall of the roof and the screw holes in the Mounting Plate.
2. When drilling the hole for the mast, you must ensure the tapered washer does not foul on the wall. You may need to adjust the template to ensure the hole is in alignment with the Wall Bracket*.
3. When tightening the Tapered Washer and Locking Plate, you must ensure the mast sits **VERTICAL** when in position and aligns with the Wall Bracket*.

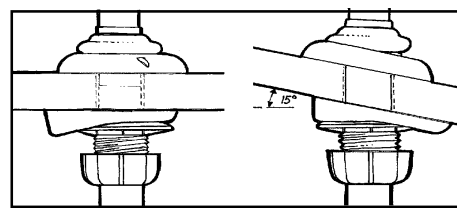

The Power Pack Positioning & Fixing

1. Locate the Power Pack in the wardrobe or locker near the mast, where it is easily accessible.

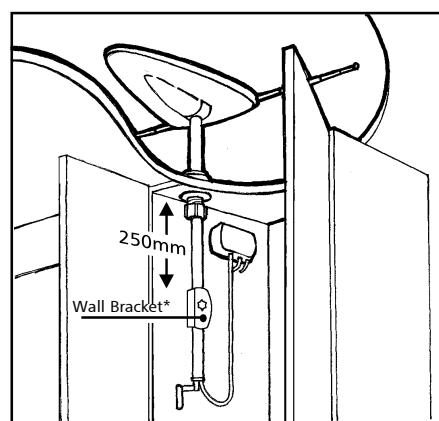

2. Fix in place using the two 16mm screws.

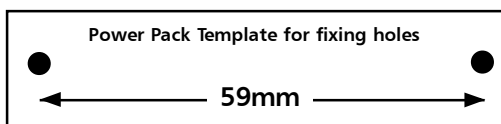

Wiring to Power Supply

1. Status requires a 12-24 volt power supply from a fused auxiliary outlet fed from the battery. If wiring direct to a battery we recommend an in-line fuse (max 5 amp) on the positive wire. If unsure please consult with a qualified installer.

RED STRIPE +VE, BLACK -VE

* Only the 530/10 comes with the additional Wall Bracket

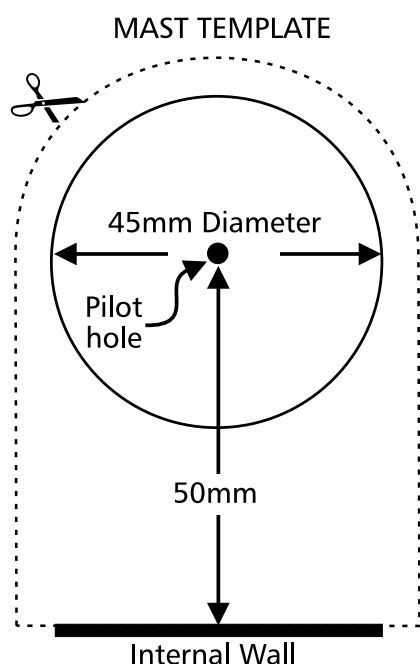

2 YEAR GUARANTEE

PLEASE COMPLETE AND RETURN TO:

Grade UK Limited,
Finch Close,
Lenton Lane Industrial Estate,
Nottingham NG7 1NN.

530 Buckleys

DO NOT connect into any other 12 volt power cables as they may carry electrical interference which will cause picture distortion.

Connecting Up the System

1. Depending on the Power Pack location, it may be necessary to shorten the cable from the Antenna to the Power Pack - **DO NOT COIL ANY EXCESS CABLE**.
2. Trim the cable and refit the Coaxial Plug as in **Important Guidelines** above. Be very careful at this stage.

IMPORTANT - It is crucial to ensure there is enough cable to raise the mast fully without stretching or kinking the coaxial cable.

3. Plug the Antenna into the 'ANT.IN' socket. **DO NOT** secure the cable, which must be left loose.
 4. Status is supplied with a 2 metre lead to connect your TV to the Power Pack. However, if your TV position is a greater distance, you will require a length of coaxial cable and two coaxial plugs, which are available from our Vision Plus Range.
 5. Plug your TV lead into the 'TV-FM' socket of the Power Pack and into your TV antenna socket.
- IMPORTANT** - When removing cables from the Power Pack, **DO NOT** pull on the cable, only the plug.

FM Radio Connection

Status is designed to receive FM radio when connected to a car-style radio.

1. This will require a coaxial car radio plug, a coaxial plug and a length of coaxial cable, which are available from our Vision Plus Range.
2. Once the cable has been installed, plug into the 'TV-FM' socket of the Power Pack and into your Radio.

IMPORTANT - You **DO NOT** need to extend the telescopes for FM radio reception.

Operating the System

Firstly determine the approximate location of the nearest transmitter and whether the signals are horizontally or vertically polarised. For assistance ask your site operator or check other antennas in the vicinity.

1. Loosen the Mast Locking Collar and Wall Bracket* and raise the antenna. Turn the mast to direct the Antenna towards the TV transmitter.

The **RED SPOT** on the bottom of the mast indicates the front of the Antenna.

2. When receiving vertically polarised signals, rotate the Winder anti-clockwise to cant the antenna through 90°. **DO NOT** over tighten or use undue force on the winder. **DO NOT** cant for vertically polarised signals with the **TELESCOPICS EXTENDED**

3. Switch **ON** the Power Pack and the red LED will illuminate.
4. Check the gain control switch is set to normal - **NML**. See Problem 2, over the page for use.
5. Tune your Television into the strongest signal. You may need to adjust the direction of the mast to achieve the best picture quality.
6. Secure by tightening the Mast Locking Collar and Wall Bracket*.

VHF Television Reception (Overseas Only)

1. Extend the two telescopic antennas.
 2. Tune your Television into the strongest signal. You may need to adjust the direction of the Antenna to achieve the best picture quality.
 3. For fine tuning of VHF you may also need to adjust the length of the telescopes.
- IMPORTANT** - VHF TV transmissions are **ONLY** horizontally polarised.

Removing the Antenna

A permanently fitted Status can be easily removed leaving only the Mounting Foot and rubber gaiter.

1. Unplug the antenna from the Power Pack.
2. Loosen the Mast Locking Collar and Wall Bracket and lift off whilst feeding out the mast and cable.
3. Push the Blanking Cap supplied into place.

IMPORTANT - The Blanking Cap is a temporary seal and is not recommended for long term use.

COMMON INTERFERENCE PROBLEMS & POSSIBLE REMEDIES

1. Weak TV Signal

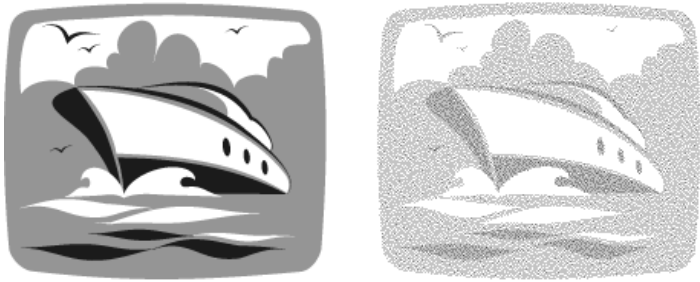

This produces a 'Snowy' picture which can be caused if you are too far away from the TV transmitter, such as in a remote area, positioned in a valley, or if there is a building, hill or other obstruction blocking the signal.

Each TV transmitter has a defined service area where reception will be good. Beyond that boundary is a 'fringe' area where the TV signal will be weaker and the reception quality poorer.

Remedy

Firstly determine whether you are in a poor reception area. Secondly check the points covered in **Fault Finding**.

2. TV Signal too strong



This can produce severe picture distortion like a zig-zag style pattern. This can be caused when you are too close to a transmitter or picking up strong radio transmissions from another source such as CB radio. Also electrical interference can cause similar effects (see Interference 4 below).

Remedy

Turn the gain control switch on the Power Pack to 'LO'. Secondly check the points covered in **Fault Finding**.

3. Ghosting



This is the type of picture you will see when the TV signal is reflected from something in your locality. The 'something' may be a local building or landmark. Your antenna is receiving both the direct signal and the reflected signal from the same transmitter.

Remedy

Adjust the direction of the antenna or try to move to a better position away from the obstruction. Unfortunately it may not always be possible to isolate your antenna from the cause of the problem.

4. Electrical Interference

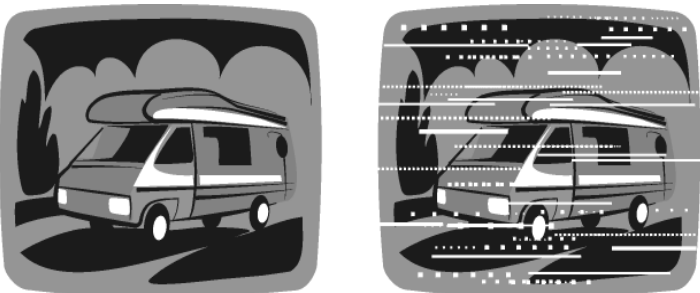

The above pictures demonstrate a typical example of electrical interference. This type of interference is commonly caused by electrical appliances, such as fans, electric shavers, fluorescent lights. Other forms of interference can produce a zig-zag pattern similar to that described in Interference 2 which may be caused by inverters, charging units etc.

Remedy

Check the points covered in **Fault Finding**. In some instances, this type of interference can be overcome by switching off the relevant appliances.

VISION PLUS STATUS 530

DIRECTIONAL TELEVISION & FM RADIO ANTENNA Installation and Operation Guide

Please read these instructions carefully. Incorrect installation will affect the performance of your Status

Dimensions:

Antenna Dome	Length	530mm
	Width-telescopic in	340mm
	width-telescopic out	1045mm
Mounting Foot	Diameter	122mm
Height	Overall	150 mm
Height	No Antenna Dome	50 mm
Power Pack		115 x 70 x 50mm

* Gain figures must not be judged in isolation. A greater figure does not mean a better picture. Status is designed for optimum performance

Conforms to the European Directive
89/336/EEC

04-3000/5 Model	485mm mast 2m Coaxial cable
04-3000/10 Model	920mm mast 5m Coaxial cable
Frequency Range	UHF 470-860 MHz
	VHF 40 -230 MHz
	FM 88 -108 MHz
Antenna Forward Gain	7db
Amplifier Gain	18 db*
Gain Adjustment	15 db
Flatness	±1.5 db
Noise Figure	3 db
Output Impedance	75 ohms
Output	98 dbuv
Power Supply	12-24 v DC
Power Consumption	35 ma
TV lead	2 metres

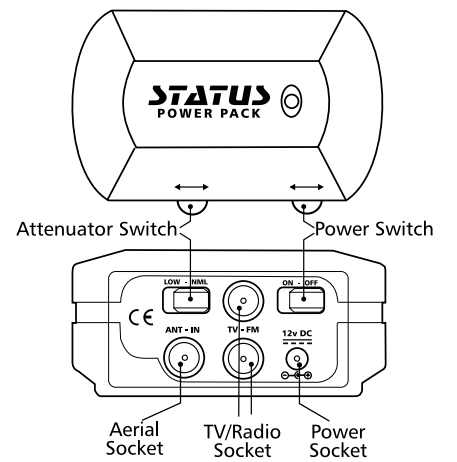
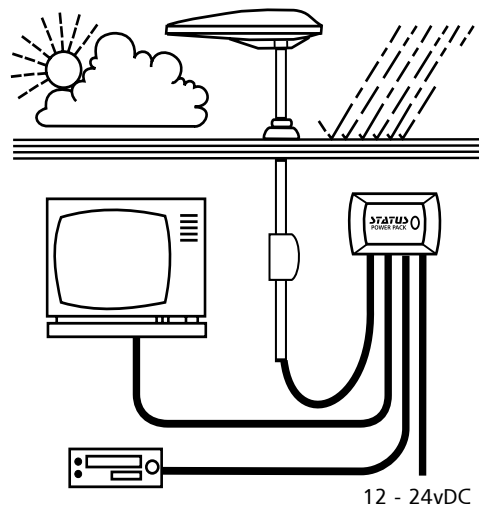

FAULT FINDING

The following are some of the key areas we suggest you check which generally solve the most common problems encountered with the operation of the Status antenna.

Coaxial Plugs

It is critical that all coaxial plugs in the system are fitted correctly. Using the diagram and procedure described over the page, please check each individual plug, ensuring it is wired correctly. Secondly please ensure only quality plugs have been used.

Coaxial Cable

Sharp bends, kinks and hot surfaces can easily damage coaxial cable and should be avoided. An inspection of the cable routing is recommended to ensure all is correct. Coaxial cable, if placed in close proximity to electrical cables, transformers or other pieces of electrical equipment, may pick up electrical interference causing picture quality to deteriorate, especially in poor reception areas. Excess cable should be removed and NOT coiled as this may cause picture distortion.

Gain Switch

Situated below the LED light on the Power Pack, this switch should be set to the normal 'NML' (switch UP) position for general use. The Low setting may be used when situated close to TV transmitters where strong signals may be affecting the quality of the picture. (see Interference2 below)

Red LED Light

Should the red LED on the Power Pack not light, first try unplugging the cable connected to the Antenna Dome from

the 'ANT-IN' socket. If the LED then illuminates the fault lies with either the coaxial plug or the coaxial cable, please refer to these areas described earlier.

If the LED is still not lit, please contact our office for further assistance.

Short Hook Up Test

This test isolates parts of your system leaving only the TV and the Status antenna linked directly together.

Firstly, unplug the coaxial plugs from the 'TV-FM' sockets of the Power Pack which will be connected to a TV outlet socket.

With your TV fly lead, connect your TV direct to the Power Pack, plugging into one of the 'TV-FM' sockets.

Ensure the antenna dome is plugged directly into the 'ANT-IN' socket of the Power Pack and switch on. Tune in your TV for the strongest signal.

If the picture quality is improved the fault lies with the wiring of the system between the Power Pack and the TV outlet socket.

Antenna Dome Coaxial Cable

Check the routing of the coaxial cable from the Antenna Dome to the Power Pack. Check to ensure there are no kinks or trapped cable or if there are loops of surplus cable which could be affecting performance.

Customer Help Line

Should you still be experiencing difficulties and require assistance, please do not hesitate to contact us at the address below.

2 YEAR GUARANTEE

Purchase Date _____

Serial Number _____

Dealer Name _____

Your Name _____

Address _____

_____ Postcode _____